

INVITATION TO BID

BID NO. 22-0015-4

**ISLANDS EXPRESSWAY AT OATLAND ISLAND ROAD OPERATIONAL
IMPROVEMENTS AND RESURFACING**

PRE-BID CONFERENCE: 10:00 AM, FEBRUARY 22, 2022
(AUDIO ONLY)

BID OPENING: 2:00 PM, MARCH 8, 2022

THE COMMISSIONERS OF CHATHAM COUNTY, GEORGIA

CHESTER A. ELLIS, CHAIRMAN

COMMISSIONER HELEN J. STONE

COMMISSIONER TANYA MILTON

COMMISSIONER LARRY RIVERS

COMMISSIONER AARON R. WHITELY

COMMISSIONER BOBBY LOCKETT

COMMISSIONER DEAN KICKLIGHTER

COMMISSIONER PATRICK J. FARRELL

COMMISSIONER KENNETH A. ADAMS

R. JONATHAN HART
COUNTY ATTORNEY

CHATHAM COUNTY, GEORGIA

DOCUMENT CHECK LIST

The following documents, when marked, are contained in and made a part of this Bid Package or are required to be submitted with the bid. It is the responsibility of the bidder to read, complete and sign, where indicated, and return these documents with his/her bid. **FAILURE TO DO SO MAY BE CAUSE FOR DISQUALIFYING THE BID.**

GENERAL INFORMATION AND INSTRUCTIONS TO BID WITH ATTACHMENTS

SURETY REQUIREMENTS - **A Bid Bond of 5% with this ITB.**

PROPOSAL

PLANS/SPECIFICATIONS - **Plans must be purchased at Clayton Digital Reprographics by logging into www.cdrepro.com. Login to DFS. New users must register. For technical support contact CDR at (912) 447-5445, fax (912) 233-7020 or email: cdwest@cdrepro.com**

BID SCHEDULE

PERFORMANCE BOND – **Required at the time of contract.**

PAYMENT BOND – **Required at the time of contract.**

CONTRACT

LEGAL NOTICE

ATTACHMENTS: A. DRUG FREE WORKPLACE; B. NONDISCRIMINATION STATEMENT; C. DISCLOSURE OF RESPONSIBILITY STATEMENT; D. CONTRACTOR & SUBCONTRACTOR AFFIDAVIT AND AGREEMENT, E. BIDDER'S CERTIFICATION REGARDING DEBARMENT, SUSPENSION, INELIGIBILITY AND VOLUNTARY EXCLUSION, F. M/WBE PARTICIPATION REPORT, G. SYSTEMATIC ALIEN VERIFICATION FOR ENTITLEMENTS, H. GOOD FAITH EFFORT GUIDELINES.

DOCUMENTATION OF ABILITY TO PERFORM BID REQUIREMENTS. THIS MAY BE REQUIRED OF BIDDERS AFTER SUBMISSION OF BIDS.

COUNTY TAX CERTIFICATE REQUIREMENT - Contractor must supply a copy of their Tax Certificate from their location in the State of Georgia, as proof of payment of the occupational tax where their office is located.

CURRENT TAX CERTIFICATE NUMBER
CITY _____
COUNTY _____
OTHER _____

The Chatham County of Commissioners have established goals to increase participation of minority and woman owned businesses. In order to accurately document participation, businesses submitting bids or proposals are encouraged to report ownership status. A minority or woman owned business is defined as a business with at least 51% ownership by one or more minority/female individuals and whose daily business operations are managed and directed by one (1) or more of the minority/female owners. Please check ownership status as applicable:

African-American _____ Asian American _____ Hispanic _____
Native American or Alaskan Indian _____ Woman _____

In the award of "Competitive Sealed Proposals", minority/female participation may be one of several evaluation criteria used in the award process when specified as such in the Request for Proposal.

RECEIPT IS HEREBY ACKNOWLEDGED OF ADDENDA NUMBER(S) _____

The undersigned bidder certifies that he/she has received the above listed and marked documents and acknowledges that his/her failure to return each, completed and signed as required, may be cause for disqualifying his/her bid.

BY: _____
DATE

SIGNATURE

TITLE: _____

COMPANY: _____

CHATHAM COUNTY, GEORGIA
OFFICE OF THE PURCHASING DIRECTOR
1117 EISENHOWER DRIVE - SUITE C
SAVANNAH, GEORGIA 31406
(912) 790-1622

Date: February 1, 2022

BID NO. 22-0015-4

GENERAL INFORMATION FOR INVITATION FOR BID

This is an invitation to submit a bid to supply Chatham County with construction, equipment, supplies and/or services as indicated herein. Sealed bids will be received at the Office of the Purchasing Director, at **The Chatham County Citizens Service Center, 1117 Eisenhower Drive, Suite C, Savannah, Georgia 31406 up to 2:00PM local time, MARCH 8, 2022.** The County reserves the right to reject **all bids that are non-responsive or not responsible.**

Instructions for preparation and submission of a bid are contained in this Invitation To Bid package. Please note that specific forms for submission of a bid are required. Bids must be typed or printed in ink.

Due to the current Pandemic, An **Audio Only Pre-Proposal Conference** has been scheduled for **FEBRUARY 22, 2022 at 10:00 AM.**, Participants may attend by calling **1-888-585-9008, conference room code 743-636-882,** to discuss the specifications and resolve any questions and/or misunderstanding that may arise. Firms attending remotely are asked to mute phones when not speaking, in consideration of others. **You are encouraged to call and participate.**

Any changes to the conditions and specifications must be in the form of a written addendum to be valid; therefore, the Purchasing Director will issue a written addendum to document each approved change. Generally when addenda are required, the bid opening date will be changed.

Chatham County has an equal opportunity purchasing policy. Chatham County seeks to ensure that all segments of the business community have access to supplying the goods and services needed by County programs. The County affirmatively works to encourage utilization of disadvantaged and minority business enterprises in our procurement activities. The County provides equal opportunity for all businesses and does not discriminate against any persons or businesses regardless of race, color, religion, age, sex, national origin or handicap.

This project IS a Special Purpose Local Option Sales Tax (SPLOST) Project. See paragraph 2.25 for MBE/WBE participation goals.

INSTRUCTIONS TO BIDDERS

1.1 **Purpose:** The purpose of this document is to provide general and specific information for use in submitting a bid to supply Chatham County with equipment, supplies, and/or services as described herein. All bids are governed by the Code of Chatham County, Chapter 4, Article IV, and the laws of the State of Georgia.

1.2 **How to Prepare Bids: All bids shall be:**

- a. Prepared on the forms enclosed herewith, unless otherwise prescribed, and **all documents must be submitted.**
- b. Typewritten or completed with pen and ink, signed by the business owner or authorized representative, with all erasures or corrections initialed and dated by the official signing the bid. **ALL SIGNATURE SPACES MUST BE SIGNED.**

Bidders are encouraged to review carefully all provisions and attachments of this document prior to submission. Each bid constitutes an offer and may not be withdrawn except as provided herein.

1.3 **How to Submit Bids: All bids shall be:**

- a. **An original and duplicate copy must be submitted in a sealed opaque envelope, plainly marked with the bid number and title, date and time of bid opening, and company name.**
- b. Mailed or delivered as follows in sufficient time to ensure receipt by the Purchasing Director on or before the time and date specified above.

1. **Mailing Address: Chatham County Purchasing and Contracting, 1117 Eisenhower Drive, Suite C, Savannah, Georgia 31406.**

2. **Hand Delivery: Purchasing Director, Chatham County Citizens Service Center, 1117 Eisenhower Drive, Suite C, Savannah, Georgia 31406.**

BIDS NOT RECEIVED BY THE TIME AND DATE SPECIFIED WILL NOT BE OPENED OR CONSIDERED.

1.4 **How to Submit an Objection:** Objections from bidders to this invitation to bid and/or these specifications should be brought to the attention of the County Purchasing Director in the following manner:

- a. When a pre-bid conference is scheduled, bidders shall either present their oral objections at that time or submit their written objections at least two (2) days prior to the scheduled pre-bid conference.
 - b. When a pre-bid conference is not scheduled, the bidder shall submit any objections he may have in writing not less than five (5) days prior to the opening of the bid.
 - c. The objections contemplated may pertain to form and/or substance of the invitation to bid documents. Failure to object in accordance with the above procedure will constitute a waiver on the part of the business to protest this invitation to bid.
- 1.5 **Failure to Bid:** If a bid is not submitted, the business should return this invitation to bid document, stating reason therefore, and indicate whether the business should be retained or removed from the County's bidders list.
- 1.6 **Errors in Bids:** Bidders or their authorized representatives are expected to fully inform themselves as to the conditions, requirements, and specifications before submitting bids. Failure to do so will be at the bidder's own risk. In case of error in extension of prices in the bid, the unit price will govern.
- 1.7 **Standards for Acceptance of Bid for Contract Award:** The County reserves the right to reject any or all bids and to waive any irregularities or technicalities in bids received whenever such rejection or waiver is in the best interest of the County. The County reserves the right to reject the bid of a bidder who has previously failed to perform properly or complete on time contracts of a similar nature, or a bid from a bidder whom investigation shows is not in a position to perform the contract.
- 1.8 **Bid Tabulation:** Tabulations for all bids will be posted for thirty (30) days after the bid opening in the Office of Purchasing and Contracting, 1117 Eisenhower Drive, Suite C, Savannah, Georgia 31406 or can be reviewed on the Purchasing web site 24/48 hours after opening at <http://purchasing.chathamcounty.org>.
- 1.9 **Bidder:** Whenever the term "bidder" is used it shall encompass the "person," "business," "contractor," "supplier," "vendor," or other party submitting a bid or proposal to Chatham County in such capacity before a contract has been entered into between such party and the County.
- 1.10 **Responsible / Responsive Bidder:** *Responsible Bidder* means a person or entity that has the capability in all respects to perform fully and reliably the contract requirements. *Responsive Bidder* means a person or entity that has submitted a bid or proposal that conforms in all material respects to the requirements set forth in the invitation for bids or request for proposals.

- 1.11 **Compliance with Laws:** The bidder and/or contractor shall obtain and maintain all licenses, permits, liability insurance, workman's compensation insurance and comply with any and all other standards or regulations required by federal, state or County statute, ordinances and rules during the performance of any contract between the contractor and the County. Any such requirement specifically set forth in any contract document between the contractor and the County shall be supplementary to this section and not in substitution thereof.
- 1.12 **Contractor:** Contractor or subcontractor means any person or business having a contract with Chatham County. The Contractor/Vendor of goods, material, equipment or services certifies that they will follow equal employment opportunity practices in connection with the awarded contract as more fully specified in the contract documents.
- 1.13 **Local Preference:** On 27 March 1998, the Board of Commissioners adopted a "**Local Vendor**" Preference Ordinance that gives the lowest Chatham County vendor submitting a responsible bid/quote the opportunity to match the lowest price offered by an out-of-County vendor. If the County vendor confirms in writing to match within 24 hours, the award will be made to the Chatham County vendor. The lowest Chatham County responsive bidder will be afforded the "right to first refusal". "Local Vendor" is defined as a business or supplier which operates and maintains a regular place of business within the geographical boundaries of Chatham County or one of the local Municipalities of the County AND all real and personal property taxes are paid prior to award of a contract or purchase. "**NOT APPLICABLE TO PUBLIC WORKS CONSTRUCTION PROJECTS AND REVENUE PRODUCING BIDS.**" However, contractors are encourage to apply the same method when awarding bids to local M/WBE businesses whenever possible in order to promote growth in Chatham County's economy.
- 1.14 **Debarred Firms and Pending Litigation:** Any potential proposer/firm listed on the Federal or State of Georgia Excluded Parties Listing (Barred from doing business) **will not** be considered for contract award. Proposers **shall disclose** any record of pending criminal violations (Indictment) and/or convictions, pending lawsuits, etc., and any actions that may be a conflict of interest occurring within the past five (5) years. Any proposer/firm previously defaulting or terminating a contract with the County will not be considered.

** All bidders or proposers are to read and complete the Disclosure of Responsibility Statement enclosed as an Attachment to be returned with response. Failure to do so may result in your solicitation response being rejected as non-responsive.

Bidder acknowledges that in performing contract work for the Board, bidder shall not utilize any firms that have been a party to any of the above actions. If bidder has engaged any firm to work on this contract or project that is later debarred, Bidder shall sever its relationship with that firm with respect to Board contract.

1.15 **Performance Evaluation:** On 11 April 2008, the Chatham County Board of Commissioners approved a change to the County Purchasing Ordinance requiring Contractor/Consultant Performance Evaluations, as a minimum, annually, prior to contract anniversary date. Should Contractor/Consultant performance be unsatisfactory, the appointed County Project Manager for the contract may prepare a Contractor/Consultant Complaint Form or a Performance Evaluation to the County Purchasing Agent.

1.16 **Payment of Taxes:** No contract shall be awarded unless all real and personal property taxes have been paid by the successful contractor and/or subcontractors as adopted by the Board of Commissioners on 8 April 1994.

1.17 **State Licensing Board for General Contractors:** Pursuant to Georgia law, the following types of contractors must obtain a license from the State Licensing Board of Residential and General Contractors by 1 July 2008 :

***Residential - Basic Contractor** (Contractor work relative to detached one-family and two-family residences and one-family townhouses not over three stories in height).

***Residential - Light Commercial Contractor** (Contractor work or activity related to multifamily and multiuse light commercial buildings and structures).

***General Contractor** (Contractor work or activity that is unlimited in scope regarding any residential or commercial projects).

See "Checklist for Submitting Bid" for the type of license required for this project.

1.18 **Immigration:** On 1 July, the Georgia Security and Immigration Compliance Act (SB 529, Section 2) became effective. All contractors and subcontractors with 100 or more employees entering into a contract or work must sign an affidavit that he/she has used the E-Verify System. E-Verify is a no-cost federal employment verification system to insure employment eligibility.

Affidavits are enclosed in this solicitation. You may download M-274 Handbook for Employers at <http://www.dol.state.ga.us/spotlight/employment/rules>. You may go to <http://www.uscis.gov> to find the E-Verify information.

Systematic Alien Verification for Entitlements (SAVE) Program: O.C.G.A. 50-36-1, required Georgia's counties to comply with the federal **Systematic Alien Verification for Entitlements (SAVE) Program**. SAVE is a federal program used to verify that applicants for certain "public benefits" are legally present in the United States. Contracts with the County are considered "public benefits." Therefore, the successful bidder will be required to provide the Affidavit Verifying Status for Chatham County Benefit Application prior to receiving any County contract. The affidavit is included as part of this bid package but is only required of the successful bidder.

Protection of Resident Workers. Chatham County Board of Commissioners actively supports the Immigration and Nationality Act (INA) which includes provisions addressing employment eligibility, employment verification, and nondiscrimination. Under the INA, employers may hire only persons who may legally work in the United States (i.e., citizens and nationals of the U.S.) and aliens authorized to work in the U.S. The employer must verify the identity and employment eligibility of anyone to be hired, which includes completing the Employment Eligibility Verification Form (I-9). The Contractor shall establish appropriate procedures and controls so no services or products under the Contract Documents will be performed or manufactured by any worker who is not legally eligible to perform such services or employment.

GENERAL CONDITIONS

- 2.1 **Specifications:** Any obvious error or omission in specifications shall not inure to the benefit of the bidder but shall put the bidder on notice to inquire of or identify the same from the County. Whenever herein mentioned is made of any article, material or workmanship to be in accordance with laws, ordinances, building codes, underwriter's codes, A.S.T.M. regulations or similar expressions, the requirements of these laws, ordinances, etc., shall be construed to be the minimum requirements of these specifications.
- 2.2 **Multiple Bids:** No vendor will be allowed to submit more than one (1) bid. Any alternate proposals must be brought to the Purchasing Agent's attention during the Pre-bid Conference or submitted in writing at least five (5) days preceding the bid opening date.
- 2.3 Not Used.
- 2.4 **Prices to be Firm:** Bidder warrants that bid prices, terms and conditions quoted in his bid will be firm for acceptance for a period of sixty (60) days from bid opening date, unless otherwise stated in the bid.
- 2.5 **Completeness:** All information required by Invitation for Bids/Proposals must be completed and submitted to constitute a proper bid or proposal.
- 2.6 **Quality:** All materials, or supplies used for the construction necessary to comply with this proposal shall be of the best quality, and of the highest standard of workmanship. Workmanship employed in any construction, repair, or installation required by this proposal shall be of the highest quality and meet recognized standards within the respective trades, crafts and of the skills employed.
- 2.7 **Guarantee/Warranty:** Unless otherwise specified by the County, the bidder shall unconditionally guarantee the materials and workmanship for one (1) year on all material and/or services. If, within the guarantee period, any defects occur which are due to faulty material and or services, the contractor at his expense, shall repair or adjust the condition, or replace the material and/or services to the complete satisfaction of the County. These

repairs, replacements or adjustments shall be made only at such time as will be designated by the County as being least detrimental to the operation of County business.

- 2.8 **Liability Provisions:** Where bidders are required to enter or go onto Chatham County property to take measurements or gather other information in order to prepare the bid or proposal as requested by the County, the bidder shall be liable for any injury, damage or loss occasioned by negligence of the bidder, his agent, or any person the bidder has designated to prepare the bid and shall indemnify and hold harmless Chatham County from any liability arising therefrom. The contract document specifies the liability provisions required of the successful bidder in order to be awarded a contract with Chatham County.
- 2.9 **Cancellation of Contract:** The contract may be canceled or suspended by Chatham County in whole or in part by written notice of default to the Contractor upon non-performance or violation of contract terms. An award may be made to the next low bidder, for articles and/or services specified or they may be purchased on the open market and the defaulting Contractor (or his surety) shall be liable to Chatham County for costs to the County in excess of the defaulted contract prices. See the contract documents for complete requirements.
- 2.10 **Patent Indemnity:** Except as otherwise provided, the successful bidder agrees to indemnify Chatham County and its officers, agents and employees against liability, including costs and expenses for infringement upon any letters patent of the United States arising out of the performance of this Contract or out of the use or disposal for the account of the County of supplies furnished or construction work performed hereunder.
- 2.11 **Certification of Independent Price Determination:** By submission of this bid, the bidder certifies, and in the case of a joint bid each party thereto certifies as to its own organization, that in connection with this procurement:
- (1) The prices in this bid have been arrived at independently, without consultation, communication, or agreement, for the purpose of restricting competition, as to any matter relating to such prices with any other bidder or with any competitor;
 - (2) Unless otherwise required by law, the prices which have been quoted in this bid have not been knowingly disclosed by the bidder and will not knowingly be disclosed by the bidder prior to opening, directly or indirectly to any other bidder or to any competitor; and
 - (3) No attempt has been made or will be made by the bidder to induce any other person or firm to submit or not be submit a bid for the purpose or restricting competition.
- 2.12 **Award of Contract:** The contract, if awarded, will be awarded to that responsible bidder whose bid/proposal will be most advantageous to Chatham County, price and other factors considered. The Board of Commissioners will make the determination as to which bid or

proposal that serves as the best value to Chatham County.

2.13 **Procurement Protests:** Objections and protests to any portion of the procurement process or actions of the County staff may be filed with the Purchasing Agent for review and resolution. The Chatham County Purchasing Procedures Manual, Article IX - Appeals and Remedies shall govern the review and resolution of all protests.

2.14 **Qualification of Business (Responsible Bidder or Proposer):** A responsible bidder or proposer is defined as one who meets, or by the date of the bid acceptance can meet, certifications, all requirements for licensing, insurance, and registrations, or other documentation required by the Design Professional engaged to develop Scope of Work, specifications and plans. These documents will be listed in the Special Conditions further on in this solicitation. Chatham County has the right to require any or all bidders to submit documentation of the ability to perform, provide, or carry out the service or provide the product requested.

Chatham County has the right to disqualify the bid or proposal of any bidder or proposer as being unresponsive or irresponsible whenever such bidder/proposer cannot document the ability to deliver the requested product.

2.15 **Chatham County Tax Certificate Requirement:** A current Chatham County Tax Certificate is required unless otherwise specified. Please contact the Building Safety and Regulatory Services at (912) 201-4300 for additional information.

NOTE: No contract shall be awarded unless all real and personal property taxes have been paid by the successful contractor and/or subcontractors as adopted by the Board of Commissioners on 8 April 1994.

2.16 **Insurance Provisions, General:** The selected contractor shall be required to procure and maintain for the duration of the contract insurance against claims for injuries to persons or damages to property which may arise from or in connection with the performance of the work hereunder by the Contractor, his agents, representatives, employees or subcontractors. The cost of such insurance shall be included in the Bid.

It is every contractor's responsibility to provide the County Purchasing and Contracting Division current and up-to-date Certificates of Insurance for multiple year contracts before the end of each term. **Failure to do so may be cause for termination of contract.**

2.16.1 General Information that shall appear on a Certificate of Insurance:

- I. Name of the Producer (Contractor's insurance Broker/Agent).
- II. Companies affording coverage (there may be several).
- III. Name and Address of the Insured (this should be the Company or Parent of the firm Chatham County is contracting with).
- IV. A Summary of all current insurance for the insured (includes effective dates

- of coverage).
- V. A brief description of the operations to be performed, the specific job to be performed, or contract number.
- VI. Certificate Holder (This is to always include Chatham County).

Chatham County as an Additional Insured: Chatham County invokes the defense of sovereign immunity. In order not to jeopardize the use of this defense, the County **is not** to be included as an Additional Insured on insurance contracts.

2.16.2 **Minimum Limits of Insurance** to be maintained for the duration of the contract:

- a. **Commercial General Liability:** Provides protection against bodily injury and property damage claims arising from operations of a Contractor or Tenant. This policy coverage includes: premises and operations, use of independent contractors, products/completed operations, personal injury, contractual, broad form property damage, and underground, explosion and collapse hazards. Minimum limits: \$1,000,000 bodily injury and property damage per occurrence and annual aggregate.
- b. **Worker's Compensation and Employer's Liability:** Provides statutory protection against bodily injury, sickness or disease sustained by employees of the Contractor while performing within the scope of their duties. Employer's Liability coverage is usually included in Worker's Compensation policies, and insures common law claims of injured employees made in lieu of or in addition to a Worker's Compensation claim. Minimum limits: \$500,000 for each accident, disease policy limit, disease each employee and Statutory Worker's Compensation limit.
- c. **Business Automobile Liability:** Coverage insures against liability claims arising out of the Contractor's use of automobiles. Minimum limit: \$1,000,000 combined single limit per accident for bodily injury and property damage. Coverage should be written on an Any Auto basis.

2.16.3 Special Requirements:

- a. **Claims-Made Coverage:** The limits of liability shall remain the same as the occurrence basis, however, the Retroactive date shall be prior to the coincident with the date of any contract, and the Certificate of Insurance shall state the coverage is claims-made. The Retroactive date shall also be specifically stated on the Certificate of Insurance.
- b. **Extended Reporting Periods:** The Contractor shall provide the County with a notice of the election to initiate any Supplemental Extended Reporting Period and the reason(s) for invoking this option.

- c. **Reporting Provisions:** Any failure to comply with reporting provisions of the policies shall not affect coverage provided in relation to this request.
- d. **Cancellation:** Each insurance policy that applies to this request shall be endorsed to state that it shall not be suspended, voided, or canceled, except after thirty (30) days prior to written notice by certified mail, return receipt requested, has been given to the County.
- e. **Proof of Insurance:** Chatham County shall be furnished with certificates of insurance and with original endorsements affecting coverage required by this request. The certificates and endorsements are to be signed by a person authorized by the insurer to bind coverage on its behalf. All certificates of insurance are to be submitted prior to, and approved by, the County before services are rendered. The Contractor must ensure Certificate of Insurance are updated for the entire term of the County.
- f. **Insurer Acceptability:** Insurance is to be placed with an insurer having an A.M. Best's rating of A and a five (5) year average financial rating of not less than V. If an insurer does not qualify for averaging on a five year basis, the current total Best's rating will be used to evaluate insurer acceptability.
- g. **Lapse in Coverage:** A lapse in coverage shall constitute grounds for contract termination by the Chatham County Board of Commissioners.
- h. **Deductibles and Self-Insured Retention:** Any deductibles or self-insured retention must be declared to, and approved by, the County. At the option of the County, either: the insurer shall reduce or eliminate such deductibles or self-insured retention as related to the County, its officials, officers, employees, and volunteers; or the Contractor shall procure a bond guaranteeing payment of related suits, losses, claims, and related investigation, claim administration and defense expenses.

2.16.4 **Additional Coverage for Specific Procurement Projects:**

- a. **Professional Liability:** Insure errors or omission on behalf of architects, engineers, attorneys, medical professionals, and consultants.

Minimum Limits:

\$1 million per claim/occurrence

Coverage Requirement:

If claims-made, retroactive date must precede or coincide with the contract effective date or the date of the Notice to Proceed. The professional must state if tail coverage has been purchased and the duration of the coverage.

- b. **Builder's Risk: (For Construction or Installation Contracts)** Covers against insured perils while in the course of construction.
Minimum Limits: All-Risk coverage equal 100% of contract value
Coverage Requirements: Occupancy Clause - permits County to use the facility prior to issuance of Notice of Substantial Completion.

- 2.17 **Compliance with Specification - Terms and Conditions:** The Invitation to Bid, Legal Advertisement, General Conditions and Instructions to Bidders, Specifications, Special Conditions, Vendor's Bid, Addendum, and/or any other pertinent documents form a part of the bidders proposal or bid and by reference are made a part hereof.

- 2.18 **Signed Bid Considered Offer:** The signed bid shall be considered an offer on the part of the bidder, which offer shall be deemed accepted upon approval by the Chatham County Board of Commissioners, Purchasing Agent or his designee. In case of a default on the part of the bidder after such acceptance, Chatham County may take such action as it deems appropriate, including legal action for damages or lack of required performance.

- 2.19 **Notice to Proceed:** The successful bidder or proposer shall not commence work under this Invitation to Bid until a written contract is awarded and a Notice to Proceed is issued by the Purchasing Agent or his designee. If the successful bidder does commence any work or deliver items prior to receiving official notification, he does so at his own risk.

- 2.20 **Payment to Contractors:** Instructions for invoicing the County for products delivered to the County are specified in the contract document.
 - a. Questions regarding payment may be directed to the Finance Department at (912) 652-7900 or the County's Project Manager as specified in the contract documents.

 - b. Contractors will be paid the agreed upon compensation upon satisfactory delivery of the products or completion of the work as more fully described in the contract document.

 - c. Upon completion of the work or delivery of the products, the Contractor will provide the County with an affidavit certifying all suppliers, persons or businesses employed by the Contractor for the work performed for the County have been paid in full.

 - d. Chatham County is a tax exempt entity. Every contractor, vendor, business or person under contract with Chatham County is required by Georgia law to pay State sales or use taxes for products purchased in Georgia or transported into Georgia and sold to Chatham County by contract. Please consult the State of Georgia, Department of Revenue, Sales and Use Tax Unit in Atlanta (404) 656-4065 for additional information.

2.21 **Owner's Rights Concerning Award:** The Owner reserves the right, and sole and complete discretion to waive technicalities and informalities. The Owner further reserves the right, and sole and complete discretion to reject all bids and any bid that is not responsive or that is over the budget, as amended. In judging whether the bidder is responsible, the Owner will consider, but is not limited to consideration of, the following:

- a. Whether the bidder or principals are currently ineligible, debarred, suspended, or otherwise excluded from bidding or contracting by any state or federal agency, department, or authority;
- b. Whether the bidder or principals have been terminated for cause or are currently in default on a public works contract;
- c. Whether the bidder can demonstrate a commitment to safety with regard to Workers' Compensation by having an experience Modification Rate (EMR) over the past three years not having exceeded an average of 1.2; and
- d. Whether the bidder's past work provides evidence of an ability to successfully complete public works projects within the established time, quality, or cost, or to comply with the bidder's contract obligations; and
- e. Whether the bidder has made a Good Faith Effort to meet local participation goals for local economic impact for Disadvantaged Business Enterprises and Small Business Enterprises.

2.22 **Owner's Right to Negotiate with the Lowest Bidder:**

In the event all responsive and responsible bids are in excess of the budget, the Owner, in its sole and absolute discretion and in addition to the rights set forth above, reserves the right either to (i) supplement the budget with additional funds to permit award to the lowest responsive and responsible bid, or (ii) to negotiate with the lowest responsive and responsible bidder (after taking all deductive alternates) only for the purpose of making changes to the Project that will result in a cost to the Owner that is within the budget, as it may be amended.

2.23 **Debarred or Suspended Subcontractors.**

CONTRACTOR shall not subcontract, and shall ensure that no subcontracts are awarded at any tier, to any individual, firm, partnership, joint venture, or any other entity regardless of the form of business organization, that is on the Federal Excluded Parties List System (EPLS) at <https://www.epls.gov> or the State of Georgia, DOAS, State Purchasing Exclusion listing, or other local government entity. This includes pending litigation or claims with the County or other government entities. Contractor shall immediately notify County in

the event any subcontractor is added to a Federal, State or other Government Entity listing after award of the subcontract.

2.24 Cone of Silence:

Lobbying of Procurement Evaluation Committee members, County Government employees, and elected officials regarding this product or service solicitation, Invitation to Bid (ITB) or Request for Proposal (RFP) or contact by any member of a proposer's staff, or those people employed by any legal entity affiliated with an organization that is responding to the solicitation is strictly prohibited.

2.25 The Chatham County Board of Commissioners has adopted an aggressive program that establishes goals for minority/female, small and disadvantaged business participation in construction, professional services, and general procurement.

a. The Chatham County Board of Commissioners under Georgia law may reject any bid as non-responsive if they feel a bidder did not exercise "Good Faith Effort" in obtaining the goal established for M/WBE participation.

b. The Chatham County Board of Commissioners adopted a policy establishing goals oriented to increase participation of minority and female owned businesses, through MBE/WBE certification and development. In order to accurately document participation, businesses submitting bids, quotes or proposals are encouraged to report ownership status. A bidder or vendor that is certified by any agency of the Federal Government or State of Georgia may submit a copy of their certification with their bid as proof of qualifications. Bidders that intend to engage in joint ventures or utilize subcontractors must submit to the County Contracts Administrator, a report on Minority/Female Business Enterprise participation.

Goals established for this project is 30% Combined.

c. A Minority/Female Business Enterprise (M/WBE) is a business concern that is at least 51% owned by one or more minority/female individuals and whose daily business operations are managed and directed by one (1) or more of the minority/female owners.

2.26 LIQUIDATED DAMAGES: Failure to complete all work within **240** calendar days plus any extension authorized in writing by the County shall entitle the County to deduct as "Liquidated Damages" from the monies due the Contractor the amount of **\$400** for each calendar day in excess of the authorized construction time.

- 2.26 Bidders or proposers are required to make a **Good Faith Effort**, where subcontracting is to be utilized in performing the contract, to subcontract with or purchase supplies from qualified Local, M/WBEs. Bidders or proposers are required to state if they intend to subcontract any part of the work. Goals will be established for each contract at the onset. **Forms** requiring the signatures of bidders or proposers are enclosed as **Attachments** and must be completed and returned with your bid response. If forms are not completed and submitted, the bid may be considered nonresponsive.

Each bidder or proposer is required to maintain records of such efforts in detail adequate to permit a determination of compliance with these requirements. All contracts will reflect **Good Faith Efforts** and reporting requirements for the term of the contract. The County particularly urges general contractors to give emphasis to subcontracting with local area firms. **For information on the program or Local, M/WBE contractors/vendors please contact Connell C. Heyward, Chatham County Local, Minority and Women Business Coordinator, 1117 Eisenhower Drive, Suite 101, Savannah, Georgia 31406, (912) 652-7828 phone, or (912) 652-7951 fax. Email: cheyward@chathamcounty.org**

- 2.27 **GEORGIA OPEN RECORDS ACT** - The responses will become part of the County's official files without any obligation on the County's part. Ownership of all data, materials and documentation prepared for and submitted to Chatham County in response to a solicitation, regardless of type, shall belong exclusively to Chatham County and will be considered a record prepared and maintained or received in the course of operations of a public office or agency and subject to public inspection in accordance with the Georgia Open Records Act, Official Code of Georgia Annotated, Section 50-18-70, et. Seq., unless otherwise provided by law.

Responses to RFPs shall be held confidential from all parties other than the County until after the contract is awarded by the Board of Commissioners.

The vendor and their bid price in response to ITBs will be read allowed at public bid openings. After Bid Tabulations, the ITB shall be available for public viewing.

Chatham County shall not be held accountable if material from responses is obtained without the written consent of the vendor by parties other than the County, at any time during the solicitation evaluation process.

- 2.28 **GEORGIA TRADE SECRET ACT of 1990** - In the event a Bidder/Proposer submits trade secret information to the County, the information must be clearly labeled as a Trade Secret. The County will maintain the confidentiality of such trade secrets to the extent provided by law.
- 2.29 **CONTRACTOR RECORDS** -The Georgia Open Records Act is applicable to the records of all contractors and subcontractors under contract with the County. This applies to those specific contracts currently in effect and those which have been completed or closed for up

three (3) years following completion.

2.30 **REFERENCES - \$500,000 or more:** For bidders to be responsive each must provide information on the most recent five (5) projects with similar scope of work as well as other information to determine experience and qualifications as follows:

a. Project Name: _____

Location: _____

Owner: _____

Address: _____

City and State: _____

Contact: _____

Phone & Fax: _____

*Architect or Engineer: _____

Contact: _____

Phone & Fax: _____

b. The awarded bid amount and project start date.

Final cost of project and completion date.

Number of change orders.

Contracted project completion in days.

Project completed on time. Yes _____ No _____ Days exceeded _____.

List previous contracts your company performed for Chatham County by Project Title, date and awarded/final cost.

Has contractor ever failed to complete a project? If so, provide explanation.

Have any projects ever performed by contractor been the subject of a claim or lawsuit by or against the contractor? If yes, please identify the nature of such claim or lawsuit, the court in which the case was filed and the details of its resolution.

\$499,000 and less: Provide references from owners of at least three (3) projects of various sizes. Include government owners if possible. If the contractor has performed any work for the Chatham County Board of Commissioners within the last five (5) years, at least one (1) of the three (3) owner references must be from the appropriate party within the Chatham County Government. Provide in the format as in (a) above on the attached form.

Failure to provide the above information may result in your firm's bid being rejected and ruled as non-responsive.

NOTE: FORMS FOR YOU TO FILL OUT FOR YOUR REFERENCES ARE ATTACHED TO THE BACK OF THIS BID PACKAGE.

ADDITIONAL CONDITIONS

- 3.1 **METHOD OF COMPENSATION.** The compensation provided for herein shall include all claims by the CONTRACTOR for all costs incurred by the CONTRACTOR in the conduct of the Project as authorized by the approved Project Compensation Schedule and this amount shall be paid to the CONTRACTOR after receipt of the invoice and approval of the amount by the COUNTY. The COUNTY shall make payments to the CONTRACTOR within thirty (30) days from the date of receipt of the CONTRACTOR's acceptable statement on forms prepared by the CONTRACTOR and approved by the COUNTY.

Should the Project begin within any one month, the first invoice shall cover the partial period from the beginning date of the Project through the last day of the month (or on a mutually agreeable time) in which it began. The invoices shall be submitted each month until the Project is completed. Invoices shall be itemized to reflect actual expenses for each individual task; also refer to the requirements concerning changes, delays and termination of work under Sections I-8, 9, and 10 of the contract. Each invoice shall be accompanied by a summary progress report which outlines the work accomplished during the billing period and any problems that may be inhibiting the Project execution. The terms of this contract are intended to supersede all provisions of the Georgia Prompt Pay Act.

As long as the gross value of completed work is less than 50% of the total contract amount, or if the contractor is not maintaining his construction schedule to the satisfaction of the engineer, the County shall retain 10% of the gross value of the completed work as indicated by the current estimate approved by the engineer.

After the gross value of completed work becomes to or exceed 50% of the total contract amount within a time period satisfactory to the County, then the total amount to be retained may be reduced to 5% of the gross value of the completed work as indicated by the current estimate approved by the engineer, until all pay items are substantially completed.

When all work is completed and time charges have ceased, pending final acceptance and final payment the amount retained may be further reduced at the discretion of the County.

The CONTRACTOR may submit a final invoice to the County for the remaining retainage upon COUNTY'S acceptance of the Certificate of Substantial Completion. Final payment constituting the entire unpaid balance due shall be paid by the COUNTY to the

CONTRACTOR when work has been fully completed and the contract fully performed, except for the responsibilities of the CONTRACTOR which survive final payment. The making of final payment shall constitute a waiver of all claims by Chatham County except those arising from unsettled liens, faulty or defective work appearing after substantial completion, failure of the work to comply with the requirements of the Contract Documents,

or terms of any warranties required by the Contractor Documents or those items previously made in writing and identified by the COUNTY as unsettled at the time of final application for payment. Acceptance of final payment shall constitute a waiver of all claims by the CONTRACTOR, except those previously made in writing and identified by the CONTRACTOR as unsettled at the time of final application for payment.

3.3 **SURETY REQUIREMENTS and Bonds:** (check where applicable)

- A.** Such bidder shall post a bid bond, certified check or money order made payable to the Chatham County Finance Department in the amount of 5% of the bid price.
- B.** Contractor(s) shall be required at time of contract to shall post a payment/performance bond, certified check or money order made payable to the Chatham County Finance Department in the amount of 100% of the bid price if awarded the purchase. Such bond(s) are due prior to contract execution as a guarantee that goods meet specifications and will be delivered per contract. Such bonds will also guarantee quality performance of services and timely payment of invoices to any subcontractors.
- C.** Whenever a bond is provided, it shall be executed by a surety authorized to do business in the State of Georgia and approved by Chatham County.
- D.** Bidder acknowledges Chatham County's right to require a Performance and Payment Bond of a specific kind and origin. "Performance Bond" means a bond with good and sufficient surety or surities for the faithful performance of the contract and to indemnify the governmental entity for any damages occasioned by a failure to perform the same within the prescribed time. Such bond shall be payable to, in favor of, and for the protection of the governmental entity for which the work is to be done. "Payment Bond" means a bond with good and sufficient surety or surities payable to the governmental entity for which the work is to be done and intended for the use and protection of all subcontractors and all persons supplying labor, materials, machinery, and equipment in the prosecution of the work provided for in the public works construction contract.
- E.** Forfeit the amount of the Bid Bond if he/she fails to enter into a contract with Chatham County to do and/or furnish everything necessary to provide service and/or accomplish the work stated and/or specified in this bid proposal for the bid amount.

3.4 **WARRANTY REQUIREMENTS:**

- a. Provisions of item 2.7 apply.
- b. Warranty required.

- X
 - 1. Standard warranty shall be offered with bid.
 - 2. Extended warranty shall be offered with bid. The cost of the extended warranty will be listed separately on the bid sheet.

3.5 **TERMS OF CONTRACT:** (check where applicable):

- a. Annual Contract (With automatic renewal options for four (4) additional one (1) year terms if all parties agree)
- b. One-time Purchase
- X c. Other **ONE TIME CONTRACT**

3.6 **AUDITS AND INSPECTIONS:**

At any time during normal business hours and as often as the County may deem necessary, the Contractor and his subcontractors shall make available to the County and/or representatives of the Chatham County Department of Internal Audit for examination of all its records with respect to all matters covered by this Contract. It shall also permit the County and/or representatives of the Department of Internal Audit to audit, inspect, examine and make copies, excerpts or transcripts from such records of personnel, conditions of employment and other data relating to all matters covered by this Contract. All documents to be audited shall be available for inspection at all reasonable times in the main offices of the County or at the offices of the Contractor as requested by the County.

CONVERSATIONS OR CORRESPONDENCE REGARDING THIS SOLICITATION OR REPORT BETWEEN PROSPECTIVE OFFERORS AND PERSONS OUTSIDE THE CHATHAM COUNTY PURCHASING OFFICE WILL NOT BE CONSIDERED OFFICIAL OR BINDING UNLESS OTHERWISE SPECIFICALLY AUTHORIZED WITHIN THIS DOCUMENT.

The undersigned bidder or proposer certifies that he/she has carefully read the preceding list of instructions to bidders and all other data applicable hereto and made a part of this invitation; and, further certifies that the prices shown in his/her bid/proposal are in accordance with all documents contained in this Invitation for Bids/ Proposals package, and that any exception taken thereto may disqualify his/her bid/proposal.

This is to certify that I, the undersigned bidder, have read the instructions to bidder and agree to be bound by the provisions of the same.

This _____ day of _____ 20 _____.

BY _____

SIGNATURE

TITLE

COMPANY

Phone / Fax No's. / e-mail

CHATHAM COUNTY, GEORGIA
SURETY REQUIREMENTS

A Bid Bond for five percent (5%) of the amount of the bid is required to be submitted with each bid.

Performance and Payment Bonds for one hundred percent (100%) of the bid shall be required of the successful bidder.

The Bidder certifies that he/she has examined all documents contained in this bid package, and is familiar with all aspects of the proposal and understands fully all that is required of the successful bidder. The Bidder further certifies that his/her bid shall not be withdrawn for thirty (30) days from the date on which his bid is publicly opened and read.

The Bidder agrees, if awarded this bid, he/she will:

- A. Furnish, upon receipt of an authorized Chatham County Purchase Order, all items indicated thereon as specified in this bid proposal for the bid amount, or;
- B. Enter a contract with Chatham County to do and/or furnish everything necessary to provide the service and/or accomplish the work as stated and/or specified in this bid proposal for the bid amount, and;
- C. Furnish, if required, a Performance Bond, and acknowledges Chatham County's right to require a Performance Bond of a specific kind and origin, and;
- D. Forfeit the amount of the Bid Bond if he/she fails to enter a contract with Chatham County as stated in (B) above, within fifteen (15) days of the date on which he/she is awarded the bid, and/or;
- E. Forfeit the amount of the Performance Bond if he/she fails to execute and fulfill the terms of the contract entered. The amount of forfeiture shall be:
 - 1. The difference between his/her bid and the next lowest, responsible bid that has not expired or been withdrawn, or;
 - 2. The difference between his/her bid and the amount of the lowest, responsible bid received as a result of rebidding, including all costs related to rebidding.

COMPANY

DATE

SIGNATURE

TITLE

TELEPHONE NUMBER

PROPOSAL

SPECIFICATIONS FOR:

BID NO. 22-0015-4

ISLANDS EXPRESWAY AT OATLAND ISLAND ROAD OPERATIONAL IMPROVEMENTS AND RESURFACING

Operational and safety improvements on Island's Expressway and Oatland Island Rd. The project includes milling, resurfacing, two foot wide paved shoulder addition, turn lanes, median break and Oatland Island Road minor widening and access improvements. Drainage and guardrail improvements are also components of this project.

Construction plans, technical specifications and some special provisions for the project are provided separately and are considered part of the contract documents.

All work under this contract shall be done in accordance with the Georgia Department of Transportation (GDOT) Standard Specifications, latest edition and subsequent supplemental specifications; the latest edition of the Manual on Uniform Traffic Control Devices (MUTCD) and the following Shelf Special Provisions

All materials used in the process of completion of the work included in the contract will be furnished from Georgia Department of Transportation certified suppliers only as per the GDOT Qualified Products List

The Prime Contractor must be pre-qualified by GDOT at the time of the bid opening. All subcontractors must be qualified or registered by GDOT prior to beginning work on the project.

This shall be a Line Item contract.

COMMENCEMENT AND COMPLETION:

WORK SHALL BEGIN WITHIN 10 DAYS AFTER RECEIPT OF "NOTICE TO PROCEED". ALL WORK SHALL BE COMPLETED WITHIN 240 CALENDAR DAYS AFTER THE TEN DAY PERIOD.

Islands Expressway At Oatland Island Road Operational Improvements and Resurfacing

BID SHEET

ITEM	DESCRIPTION	UNITS	QUANTITY	UNIT PRICE	TOTAL
ROADWAY					
150-1000	TRAFFIC CONTROL - FOR OPERATIONAL IMPROVEMENTS	LS	1		
150-1001	TRAFFIC CONTROL FOR RESURFACING	LS	1		
207-0203	FOUND BKFILL MATL, TP II	CY	70		
210-0100	GRADING COMPLETE - FOR OPERATIONAL IMPROVEMENTS	LS	1		
210-0101	GRADING COMPLETE FOR RESURFACING	LS	1		
310-1101	GR AGGR BASE CRS, INCL MATL	SY	2300		
318-3000	AGGR SURF CRS	TN	60		
402-1812	RECYCLED ASPH CONC LEVELING, INCL BITUM MATL & H LIME	TN	2830		
402-3121	RECYCLED ASPH CONC 25 MM SUPERPAVE, GP 1 OR 2, INCL BITUM MATL & H LIME	TN	1150		
402-3130	RECYCLED ASPH CONC 12.5 MM SUPERPAVE, GP 2 ONLY, INCL BITUM MATL & H LIME	TN	5700		
402-3102	RECYCLED ASPH CONC 9.5 MM SUPERPAVE, TYPE II, BLEND 1, INCL BITUM MATL & H LIME	TN	450		
402-3190	RECYCLED ASPH CONC 19 MM SUPERPAVE, GP 1 OR 2, INCL BITUM MATL & H LIME	TN	320		
413-0750	TACK COAT	GL	5400		
432-5010	MILL ASPH CONC PVMT, VARIABLE DEPTH	SY	14200		
441-0016	DRIVEWAY CONCRETE, 6 IN TK	SY	50		
441-0050	CONC SLOPE DRAIN	SY	20		
441-0301	CONC SPILLWAY, TP 1	EA	1		
441-0302	CONC SPILLWAY, TP 2	EA	1		
441-0303	CONC SPILLWAY, TP 3	EA	1		
441-6216	CONC CURB & GUTTER, 8 IN X 24 IN, TP 2	LF	170		
446-1100	PVMT REINF FABRIC STRIPS, TP 2, 18 INCH WIDTH	LF	10280		
456-2016	INDENTATION RUMBLE STRIPS - GROUND-IN-PLACE (SKIP)	GLM	2.74		
500-3200	CLASS B CONCRETE	CY	1		
500-9999	CLASS B CONC, BASE OR PVMT WIDENING	CY	3		
550-1150	STORM DRAIN PIPE, 15 IN, H 1-10	LF	5		
550-1180	STORM DRAIN PIPE, 18 IN, H 1-10	LF	600		
550-3318	SAFETY END SECTION 18 IN, STORM DRAIN, 4:1 SLOPE	EA	2		
576-1010	SLOPE DRAIN PIPE, 10 IN	LF	40		
611-3030	RECONSTR STORM SEWER MANHOLE, TYPE 1	EA	2		
611-8040	ADJUST DROP INLET TO GRADE	EA	2		
641-1100	GUARDRAIL, TP T	LF	190		
641-1200	GUARDRAIL, TP W	LF	900		
641-5001	GUARDRAIL ANCHORAGE, TP 1	EA	3		
641-5015	GUARDRAIL TERMINAL, TP 12A, 31 IN, TANGENT, ENERGY-ABSORBING	EA	4		
643-8200	BARRIER FENCE (ORANGE), 4 FT	LF	3650		
668-2100	DROP INLET, GP 1	EA	6		
900-0039	BRICK PAVERS	SF	300		
TEMPORARY EROSION CONTROL					
163-0232	TEMPORARY GRASSING	AC	8		
163-0240	MULCH	TN	180		
163-0301	CONSTRUCT AND REMOVE CONSTRUCTION EXITS	EA	2		
163-0503	CONSTRUCT AND REMOVE SILT CONTROL GATE, TP 3	EA	4		
163-0527	CONSTRUCT AND REMOVE RIP RAP CHECK DAMS, STONE PLAIN RIP RAP/SAND BAGS	EA	21		
163-0529	CONSTRUCT AND REMOVE TEMPORARY SEDIMENT BARRIER OR BAILED STRAW CHECK DAM	LF	110		

163-0550	CONSTRUCT AND REMOVE INLET SEDIMENT TRAP	EA	8		
165-0010	MAINTENANCE OF TEMPORARY SILT FENCE, TP A	LF	1280		
165-0030	MAINTENANCE OF TEMPORARY SILT FENCE, TP C	LF	7180		
165-0041	MAINTENANCE OF CHECK DAMS - ALL TYPES	LF	400		
165-0071	MAINTENANCE OF SEDIMENT BARRIER - BAILED STRAW	LF	110		
165-0087	MAINTENANCE OF SILT CONTROL GATE, TP 3	EA	4		
165-0101	MAINTENANCE OF CONSTRUCTION EXIT	EA	2		
165-0105	MAINTENANCE OF INLET SEDIMENT TRAP	EA	8		
167-1000	WATER QUALITY MONITORING AND SAMPLING	EA	6		
167-1500	WATER QUALITY INSPECTIONS	MO	6		
171-0010	TEMPORARY SILT FENCE, TYPE A	LF	1280		
171-0030	TEMPORARY SILT FENCE, TYPE C	LF	7180		
PERMANENT EROSION CONTROL					
603-2181	STN DUMPED RIP RAP, TP 3, 18 IN	SY	20		
603-7000	PLASTIC FILTER FABRIC	SY	20		
700-6910	PERMANENT GRASSING	AC	4		
700-7000	AGRICULTURAL LIME	TN	20		
700-8000	FERTILIZER MIXED GRADE	TN	3		
700-8100	FERTILIZER NITROGEN CONTENT	LB	200		
716-2000	EROSION CONTROL MATS, SLOPES	SY	40		
SIGNING & MARKING					
636-1033	HIGHWAY SIGNS, TP 1 MATL, REFL SHEETING, TP 9	SF	97		
636-1036	HIGHWAY SIGNS, TP 1 MATL, REFL SHEETING, TP 11	SF	190		
636-1041	HIGHWAY SIGNS, TP 2 MATL, REFL SHEETING, TP 9	SF	35		
636-2070	GALV STEEL POSTS, TP 7	LF	578		
636-2080	GALV STEEL POSTS, TP 8	LF	36		
653-0120	THERMOPLASTIC PVMT MARKING, ARROW, TP 2	EA	12		
653-0170	THERMOPLASTIC PVMT MARKING, ARROW, TP 7	EA	4		
653-1501	THERMOPLASTIC SOLID TRAF STRIPE, 5 IN, WHITE	LF	17420		
653-1502	THERMOPLASTIC SOLID TRAF STRIPE, 5 IN, YELLOW	LF	21270		
653-1704	THERMOPLASTIC SOLID TRAF STRIPE, 24 IN, WHITE	LF	120		
653-3501	THERMOPLASTIC SKIP TRAF STRIPE, 5 IN, WHITE	GLF	14550		
653-6006	THERMOPLASTIC TRAF STRIPING, YELLOW HATCHING	SY	1630		
654-1001	RAISED PVMT MARKERS TP1	EA	65		
654-1003	RAISED PVMT MARKERS TP2	EA	350		
999-1000	FIELD CONDITION ALLOWANCE	LS	1	\$ 50,000.00	
				TOTAL BID	
CARRY ITEM TOTALS TO TWO DECIMAL PLACES, ROUND OFF TOTAL BID TO WHOLE DOLLAR					

Name/ Title

Company

Address

Phone/ Fax Numbers

E-mail

ISLANDS EXPRESSWAY RESURFACING PROJECT -SUMMARY OF QUANTITIES

	TRAFFIC CONTROL	LS	1
	GRADING COMPLETE	LS	1
	RECYCLED ASPH CONC LEVELING, INCL BITUM MATL & H LIME	TN	200
	RECYCLED ASPH CONC 12.5 MM SUPERPAVE, GP 2 ONLY, INCL BITUM MATL & H LIME	TN	2960
	TACK COAT	GL	3580
	MILL ASPH CONC PVMT, VARIABLE DEPTH	SY	12360
	INDENTATION RUMBLE STRIPS - GROUND-IN-PLACE (SKIP)	GLM	2.74
	THERMOPLASTIC PVMT MARKING, ARROW, TP 7	EA	1
	THERMOPLASTIC SOLID TRAF STRIPE, 5 IN, WHITE	LF	8826
	THERMOPLASTIC SOLID TRAF STRIPE, 5 IN, YELLOW	LF	9542
	THERMOPLASTIC SOLID TRAF STRIPE, 24 IN, WHITE	LF	12
	SOLID TRAFFIC STRIPE, 10 IN, WHITE	LF	1228
	THERMOPLASTIC SKIP TRAF STRIPE, 5 IN, WHITE	GLF	7100
	THERMOPLASTIC TRAF STRIPING, YELLOW HATCHING	SY	1238
	RAISED PVMT MARKERS TP 1	EA	28
	RAISED PVMT MARKERS TP 3	EA	272

LIST OF SUBCONTRACTORS

I do _____, do not _____, propose to subcontract some of the work on this project. I propose to subcontract work to the following subcontractors: **NOTE: M/WBE PARTICIPATION.**

<i>NAME AND ADDRESS</i>	<i>TYPE OF WORK</i>

SIGNED: _____ CONTRACTOR

SPECIAL CONDITIONS
ISLANDS EXPRESSWAY AT OATLAND ISLAND OPERATIONAL IMPROVEMENTS
and RESURFACING

1. DESCRIPTION OF WORK:

The work will consist of furnishing all materials, labor and equipment for:

Operational and safety improvements on Island's Expressway and Oatland Island Rd. The project includes milling, resurfacing, two foot wide paved shoulder addition, turn lanes, median break and Oatland Island Road minor widening and access improvements. Drainage and guardrail improvements are also components of this project.

Construction plans, technical specifications and some special provisions for the project are provided separately and are considered part of the contract documents.

All work under this contract shall be done in accordance with the Georgia Department of Transportation (GDOT) Standard Specifications, latest edition and subsequent supplemental specifications; the latest edition of the Manual on Uniform Traffic Control Devices (MUTCD) and the following Shelf Special Provisions which are available on the GDOT website at: http://www.dot.ga.gov/PartnerSmart/Business/Source/special_provisions/shelf/sp150.pdf)

Contract administration and inspection will be performed by Chatham County and/or its Consultants.

All materials used in the process of completion of the work included in the contract will be furnished from Georgia Department of Transportation certified suppliers only as per the GDOT Qualified Products List available on the website www.dot.ga.gov/PS/Materials/QPL.

The Prime Contractor must be pre-qualified by GDOT at the time of the bid opening. All subcontractors must be qualified or registered by GDOT prior to beginning work on the project. All subcontractors must be listed in the bid package or approved by the County in writing prior to performing work on the project.

It is the responsibility of the bidder to carefully examine and fully understand the construction contract, plans, technical specifications and other documents hereto attached and make a personal examination of the site of the proposed work, and satisfy him or herself as to the actual conditions and requirements of the work. All questions concerning the contract and/or work to be performed will be made in writing. All responses are to be made in writing. No verbal responses are to be considered when bidding this project.

The bidder further agrees that the cost of any work performed, materials furnished, services provided, or expenses incurred, which are not specifically delineated in the contract documents but which are incidental to the scope, intent, and completion of the contract, shall be deemed to have been included in the prices bid for the various items scheduled.

2. COMMENCEMENT AND COMPLETION: The Contractor shall agree to commence work under this contract within ten (10) working days after the Notice to Proceed is issued, and complete all work within 240 calendar days after the 10-day period. The Contractor shall work

continuously on the project after the Notice to Proceed is issued. Time charges will stop when all pay item work is complete.

Intermediate Deadlines - Milled pavement shall be resurfaced within 7 calendar days.

The Contractor shall notify the County when the work is substantially complete by submitting in writing a request for a Certificate of Substantial Completion (Substantial Completion shall mean the date when the work has progressed to the point where it can be utilized for the purpose for which it is intended). The Certificate shall be a mutually agreed upon document listing the date of substantial completion, items of the work remaining to be completed or corrected and shall fix the time with which the Contractor shall complete items listed therein. The Certificate shall be signed by the Contractor and Chatham County. The Contractor will have 45 days to complete any punchlist work after a final inspection is performed and the punchlist is provided. Time charges will resume after 45 days and continue until all punchlist work is complete.

3. **MAINTENANCE:** Once the Notice to Proceed has been issued, the Contractor is held responsible for **all** maintenance within the limits of the project throughout the duration of the contract without exception.

4. **LIQUIDATED DAMAGES:** Failure to complete all work within 240 calendar days plus any extension authorized in writing by the County Engineer shall entitle the County to deduct as "Liquidated Damages" from the monies due the Contractor the amount of \$ 400 for each calendar day in excess of the authorized construction time. The Georgia Department of Transportation schedule for liquidated damages will not be used.

Failure to overlay milled pavement areas as outlined above in the section for Commencement and Completion plus any extension authorized in writing by the County Engineer shall entitle the County to deduct as "Liquidated Damages" from the monies due the Contractor the amount of \$200 for each calendar day in excess of authorized construction time and the Contractor will be required to make corrections or complete any patching required due to traffic on exposed surfaces at their own expense.

Failure to complete the punchlist work within 45 days after the contract time of 240 calendar days shall entitle the County to deduct as "Liquidated Damages" from the monies due the Contractor the amount of \$200 for each calendar day in excess of authorized construction time plus 45 days for completion of punchlist work.

5. **PRECONSTRUCTION CONFERENCE:** The Contractor shall attend a pre-construction conference prior to commencing any work. The Project Manager and Project Superintendent need to be in attendance.

6. **CONSTRUCTION SCHEDULE:** The Contractor shall prepare a detailed schedule showing progress dates and completion dates of all phases of construction, including the critical path for the project. The schedule must be submitted and approved prior to commencement of work.

7. **PAYMENT:** Quantities are approximate and payment shall be for measurements of actual in-place work as per the plans and specifications. Any quantities exceeding the contract amount shall be requested by the Contractor in writing, for approval by the County Engineer, prior to the work

being performed. Payment will not be made for additional quantities without prior, written approval of the County Engineer.

8. **TRAFFIC CONTROL:** Traffic Safety is paramount. All roads must be open to traffic at all times. The Contractor will be responsible for all traffic control, in accordance with the Manual on Uniform Traffic Control Devices, GDOT standards and details, Special Provision 150 and all other safety measures that will enhance the safety of the construction site. All costs associated with this work shall be included in the bid price for traffic control. The Contractor shall submit a traffic control plan for approval prior to beginning any work. Any changes to the approved traffic control plan must be submitted and approved in writing. No more than one lane in each direction can be closed at one time. Westbound lane closures on Islands Expressway are not allowed between 6 am and 8:30 am and eastbound lane closures are not allowed between 4:30 pm and 6:30 pm.

The Contractor shall coordinate traffic control measures with Prince Contracting, LLC, contractors for the Replacement of the Islands Expressway Bridges over the Wilmington River (P.I.0007128) project west of and adjacent to this project.

9. **INCIDENTAL ITEMS OF CONSTRUCTION:** The cost associated with any incidental items of construction, in which no specific pay items are set up, shall be included in the overall cost of the project.

10. **FORCE ACCOUNT:** When no agreement is reached for additional work to be done at Lump Sum or Unit Prices, then such additional work shall be done based on the following Cost-Plus-Percentage basis of payment. The Georgia Department of Transportation specifications for the use of a force account will not be used.

a. For work performed by the prime contractor/general contractor, the contractor shall be reimbursed for actual cost incurred in doing the work, and an additional payment of 15% to cover overhead and profit.

b. For work performed by a sub-contractor, the sub-contractor shall be reimbursed for actual cost incurred in doing the work, and an additional payment of 10% to cover overhead and profit. The contractor shall be allowed an overhead and profit mark-up not to exceed 7% on the subcontractor's price. The County shall not recognize subcontractors of subcontractors.

c. The term "Actual Cost" shall include the cost of material and labor as follows:

I. Material cost - Direct cost of material, sales tax, freight and equipment rental.

ii. Labor cost - Man hour cost listed separately by trade, payroll costs including workman's compensation, social security, pension and retirement.

d. The term "Overhead and Profit" shall include bonds (Payment & Performance, Roof & Wall), insurance (Liability, Builders Risk), permits, supervision costs (cost of subcontractor to supervise own work, cost of contractor to supervise work of sub-contractor), proposal preparation and all administrative costs.

11. **PRECONSTRUCTION INSPECTION:** A preconstruction DVD or CD of video or photographs is required and must be submitted to Chatham County Department of Engineering for approval prior to the start of work. Each project section should be filmed and labeled individually

on the submittal. Special emphasis shall be given to record the existing condition of roadway pavement, signs, driveways, utilities and any other improvements within 50 feet of the project limits.

12. **WORK HOURS:** Contractor work hours shall be restricted to daylight hours on weekdays unless specifically approved otherwise at least 48 hours in advance. Approval is at the discretion of the County Engineer.

13. **UTILITIES:** The Contractor will be responsible for all utility coordination and protection of utility facilities. Contractor shall comply with Georgia Law by ensuring buried utilities are properly marked. They may do so by contacting 811 or via website www.georgia811.com or by submitting a request online or by telephone. Contractor shall perform no work until the site is marked, or that the Georgia811 organization indicates there are no buried utilities at that location. Contractor shall conform to all requirements of the Specifications as they relate to the cooperation with utility owners and protection of utility installations that exist on the project. Refer to the requirements of Section 107, Legal Regulations and Responsibility to the Public, with particular attention to Subsection 107.21. Coordinate The Work with any work to be performed by others in any right of way clearance and arrange a schedule of operations that will allow for completion of the Project within the specified contract time. Where stage construction is required, notify the utility owner when each stage of work is completed and the site is available for utility work to proceed. In accordance with Subsection 105.06 of the Specifications, Chatham County is not liable for payment of any claims due to utility delays, inconvenience or damage sustained by the Contractor due to interference of any utilities or appurtenances, or the operation of moving them.

14. **PRIME CONTRACTOR SUPERINTENDENT:** A qualified Superintendent of the prime contractor shall be on-site at all times during construction activities, including those of subcontractors. A sub-contractor will not be an approved representative of the prime contractor. If the Superintendent is not present to control the work, work may be suspended by County personnel until such time as the Superintendent is on-site and has adequately addressed any problems or concerns.

15. **PERMIT:** Contractor shall obtain a right of way encroachment permit for the work along Islands Expressway and Oatland Island Road from the Chatham County Department of Public Works.

16. **SAMPLING AND TESTING OF MATERIALS:** All sampling and testing services shall be performed by an independent testing agency which operates in accordance to ASTM D3470 and E329, latest edition and accepted by the County Engineer, at the Contractor's expense. All sampling testing required for the project will be in accordance with the GDOT Sampling, Testing and Inspection Guidelines except as modified here. It is understood that these are the minimum testing requirements and that additional testing may be requested by the Engineer, as needed. A minimum of 24 hours notice shall be given to the County Project Manager prior to work which requires testing. A copy of all test reports shall be sent to the Project Manager and must be received prior to placement of the next lift if applicable and prior to any payment for the work. Written field reports are acceptable for compaction testing to expedite construction. Verbal approval will not be acceptable. The cost associated with testing shall be included in the bid price for that item.

A. Section 207 Backfill for Minor Structures - One sample per major soil type shall be taken to ensure that the material meets requirements for Class I or II Roadway Materials as per GDOT Standard Specification 810.2.01. One in-place density test shall be taken for every three lines of longitudinal pipe between drainage structures or every 500 feet, whichever is less. One in-place density test shall be taken for every line of storm drain pipe installed under road pavement. One in-place density test shall be taken for every three drainage structures. Required compaction is 95% of the maximum dry density with optimum moisture content as determined by the testing agency. Testing as per GDT 7.

B. Section 208 Embankment- One sample per major soil type shall be taken to ensure that the material meets the requirement for Class IIB3 or better soils as per GDOT Standard Specification 810.2.01. One in-place density test shall be taken per area of embankment constructed at one time on every other lift, or every 2,000 cubic yards, whichever is less. Required compaction is a minimum of 95% of the maximum dry density and optimum moisture content as determined by the testing agency. Any areas that fail a compaction test must pass a retest prior to any additional embankment being placed at that location. Testing as per GDT 7, 20, 21, 24a, 24b, 59, 67.

C. Section 209 Subgrade - One in-place density test shall be taken per every 500 linear feet, maximum 24 foot width, for each section set up at one time, of subgrade under the pavement. Subgrade testing under miscellaneous concrete or shoulders shall be at intervals of no less than 500 ft. for each section set up at one time. Compaction shall be a minimum of 100% of maximum dry density and optimum moisture content as determined by the testing agency. Any areas that fail a compaction test must pass a retest prior to placement of subsequent lift. The subgrade shall be proof rolled with a loaded dump truck and approved by the Engineer prior to placement of any base course. Testing as per GDT 7, 20, 24a, 24b, 59, 67. D. Section 310 Graded Aggregate Construction - One thickness measurement and one in-place density test per 500 linear feet, maximum 24 foot width, for each section set up at one time. Sections over 8 inches in depth will require testing in two lifts. A proof roll with a loaded dump truck may be required by the Engineer prior to placement of any asphalt or bituminous prime coat. Testing as per GDT 21,59.

E. Section 400 & 402 Hot Mix Asphalt Construction – The Contractor is responsible for all Quality Control testing as required in Section 400 (On-system) and the Contractor shall hire an independent Testing Agency to perform Comparison Testing, Quality Assurance and Acceptance Testing as per Section 400 (On-system) with the following revisions:

1. Use of a Materials Transfer Vehicle (MTV) will not be required.
2. The adjustment period for density will be one day for each mix on each road.
3. Maximum air voids for all Superpave mixes must not exceed 7.8 percent for 100% pay factor on Oatland Island Road. Air voids must not exceed 7.0 for Islands Expressway.
4. Laser road profile testing will not be completed. Contractor is to achieve the smoothest possible ride during construction.

The Testing Agency shall report density and voids to the nearest 0.1 on Form OMR-TM-150 and shall provide an Asphaltic Concrete Lot Report (similar to DOT159 and 159-5) with compaction, extraction, sieve and A/C test results and corresponding recommended pay factors for each Lot. These reports will be required prior to payment. This testing may be waived by the Engineer for projects with a total less than 500 tons of asphalt.

F. Section 441 Miscellaneous Concrete - One set of test cylinders per each 100 cumulative cubic yards or one set per week if placement is less than 100 cumulative cubic yards per week. Air and slump test are required when cylinders are made and at least once each day when concrete is placed. Additional tests may be required as necessary to insure adequate control. Cylinders shall be tested at 28 days in accordance with ASTM C39.

G. Section 500 Concrete Structures - Two sets of test cylinders per each 50 cubic yards or fraction thereof placed daily per structure. Air and slump tests are required when cylinders are made and approximately every third load thereafter to insure adequate control. Cylinders for certain items such as pipe headwalls, class B pavement widening or other miscellaneous items may follow the cylinder requirements for Section 441 or may be waived as determined by the Engineer. Cylinders shall be tested at 7 and 28 days in accordance with ASTM C39. Additional cylinders may be taken for early breaks as necessary.

17. **GRADING COMPLETE- RESURFACING:** Grading Complete for this project should include but is not limited to: borrow material, hauling and placing or excavating material as needed, grading shoulders and slopes and other miscellaneous work as required.

18. **FIELD CONDITION ALLOWANCE:** The field condition allowance shown on the bid sheet shall belong to Chatham County. The purpose of this Allowance is to allow the County to designate actions associated with completion of the project which are not indicated on the plans, but which are dictated by field conditions. Bidders shall not use this Allowance to assume any Contractor costs known or unknown at the bidding. Chatham County must approve use of the Allowance. All bidders shall include this Field Condition Allowance within their base bid. Any unused allowance shall revert to Chatham County.

19. **PLAN MODIFICATIONS:** The following modifications are made to the project plans: Additional pavement resurfacing is a component of this project. This work is in addition to the provided plan set prepared by VHB dated 09/3/2021. This additional pavement resurfacing area is located between Richardson Creek Bridge and US 80 flyover bridge and ramps shown on the Location Map.

20. **GRADED AGGREGATE BASE:** The graded aggregate base will be granite only, Limerock and recycled or crushed concrete are not approved base materials for this project.

21. **STORMWATER STRUCTURES CLEANING AND AS-BUILTS:** The Contractor is responsible for submitting digital As-built Information within 30 days of completion of construction. As-built information will include elevations and locations for all the constructed drainage structure tops and inverts (including flared end, safety end sections and headwalls) as well as connected downstream existing piping and structures. All drainage structures and storm drain pipe constructed as shown on the plans as well as connected downstream pipes within project limits shall be cleaned out at project completion.

TYPICAL SECTION 1

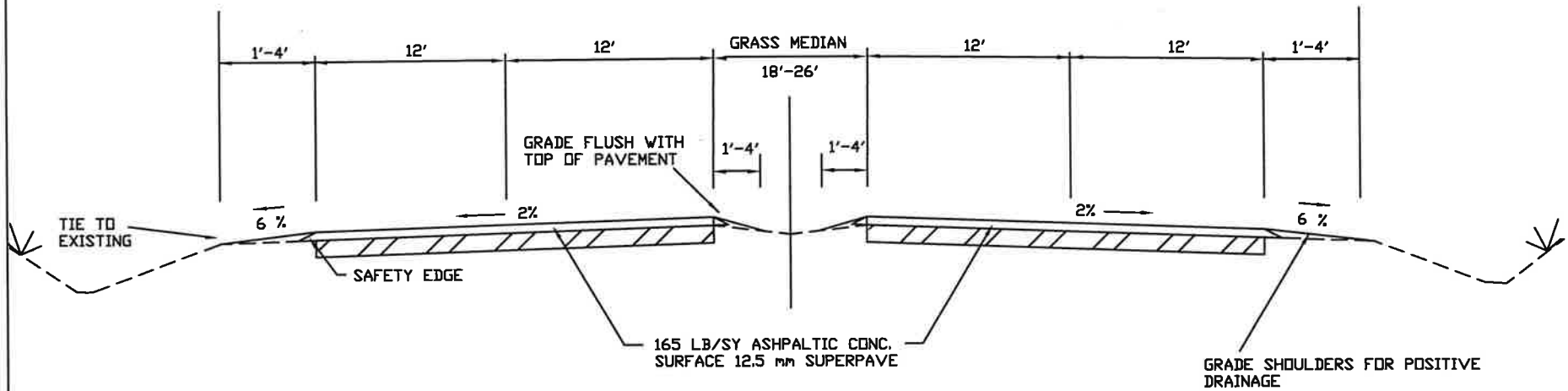

NOTES

1. MILL APPROXIMATELY 50 FT AT THE BRIDGE APPROACH FOR TIE-IN.
2. REPAVE SHOULDERS (0-10') AND CENTER MEDIAN (16') WHERE PAVEMENT IS EXISTING NEAR BRIDGE.
3. RESTRIPE PAVEMENT MARKINGS AS PER EXISTING.

ISLANDS EXPRESSWAY FOUR LANE WITH MEDIAN RESURFACING

CHATHAM COUNTY
DEPARTMENT OF ENGINEERING

SCALE: N.T.S.
DATED: JAN 2022



TYPICAL SECTION 2

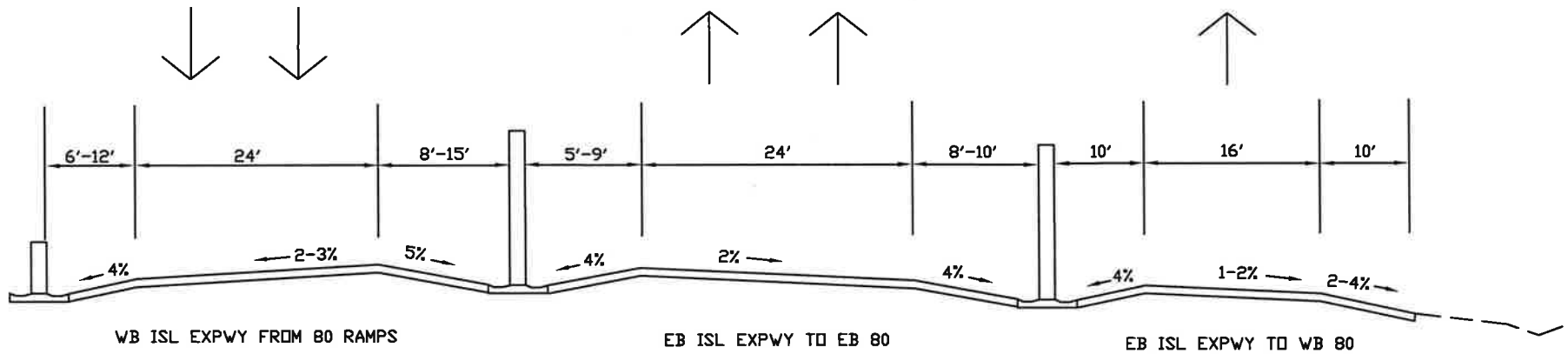

MILL ALL FULL WIDTH 1.5' BELOW GUTTER AND INLAY WITH 165 LB/SY ASPHALTIC CONCRETE SURFACE 12.5MM SUPERPAVE
 ADJUST MILLING FOR SLOPE CORRECTION OR SPOT LEVEL AS DIRECTED BY THE ENGINEER

ISLANDS EXPRESSWAY BRIDGE APPROACH AND RAMPS RESURFACING

CHATHAM COUNTY
DEPARTMENT OF ENGINEERING

SCALE: N.T.S.
 DATED: January 2022



ATTACHMENT A

DRUG - FREE WORKPLACE CERTIFICATION

THE UNDERSIGNED CERTIFIES THAT THE PROVISIONS OF CODE SECTIONS 50-24-1 THROUGH 50-24-6 OF THE OFFICIAL CODE TO GEORGIA ANNOTATED, RELATED TO THE **DRUG-FREE WORKPLACE**, HAVE BEEN COMPLIED WITH IN FULL. THE UNDERSIGNED FURTHER CERTIFIES THAT:

1. A Drug-Free Workplace will be provided for the employees during the performance of the contract; and
2. Each sub-contractor under the direction of the Contractor shall secure the following written certification:

_____ (CONTRACTOR)
certifies to Chatham County that a Drug-Free Workplace will be provided for the employees during the performance of this contract known as procurement **Islands Expressway at Oatland Island Road Operational Improvements and Resurfacing** (PROJECT) pursuant to paragraph (7) of subsection (B) of Code Section 50-24-3. Also, the undersigned further certifies that he/she will not engage in the unlawful manufacture, sale, distribution, possession, or use of a controlled substance or marijuana during the performance of the contract.

CONTRACTOR

DATE

NOTARY

DATE

ATTACHMENT B

PROMISE OF NON-DISCRIMINATION STATEMENT

Know All Men By These Presence, that I (We), _____
Name

Title Name of Bidder

(herein after Company) in consideration of the privilege to bid/or propose on the following Chatham County project procurement **Islands Expressway at Oatland Island Road Operational Improvements and Resurfacing** hereby consent, covenant and agree as follows:

- (1) No person shall be excluded from participation in, denied the benefit of or otherwise discriminated against on the basis of race, color, national origin or gender in connection with the bid submitted to Chatham County or the performance of the contract resulting therefrom;
- (2) That it is and shall be the policy of this Company to provide equal opportunity to all business persons seeking to contract or otherwise interested with the Company, including those companies owned and controlled by racial minorities, and women;
- (3) In connection herewith, I (We) acknowledge and warrant that this Company has been made aware of, understands and agrees to take affirmative action to provide minority and women owned companies with the maximum practicable opportunities to do business with this Company on this contract;
- (4) That the promises of non-discrimination as made and set forth herein shall be continuing throughout the duration of this contract with Chatham County;
- (5) That the promises of non-discrimination as made and set forth herein shall be and are hereby deemed to be made a part of and incorporated by reference in the contract which this Company may be awarded;
- (6) That the failure of this Company to satisfactorily discharge any of the promises of non-discrimination as made and set forth above may constitute a material breach of contract entitling the County to declare the contract in default and to exercise appropriate remedies including but not limited to termination of the contract.

Signature

Date

ATTACHMENT C

DISCLOSURE OF RESPONSIBILITY STATEMENT

Failure to complete and return this information will result in your bid/offer/proposal being disqualified from further competition as non-responsive.

1. List any convictions of any person, subsidiary, or affiliate of the company, arising out of obtaining, or attempting to obtain a public or private contract or subcontract, or in the performance of such contract or subcontract.

2. List any indictments or convictions of any person, subsidiary, or affiliate of this company for offenses such as embezzlement, theft, fraudulent schemes, etc. or any other offenses indicating a lack of business integrity or business honesty which affects the responsibility of the contractor.

3. List any convictions or civil judgments under states or federal antitrust statutes.

4. List any violations of contract provisions such as knowingly (without good cause) to perform, or unsatisfactory performance, in accordance with the specifications of a contract.

5. List any prior suspensions or debarments by any governmental agency.

6. List any contracts not completed on time.

7. List any penalties imposed for time delays and/or quality of materials and workmanship.

8. List any documented violations of federal or any state labor laws, regulations, or standards, occupational safety and health rules.

I, _____, as _____
Name of individual Title & Authority

of _____, declare under oath that

Company Name _____

the above statements, including any supplemental responses attached hereto, are true.

Signature

State of _____

County of _____

Subscribed and sworn to before me on this _____ day of _____

20__ by _____ representing him/herself to be

_____ of the company named herein.

Notary Public

My Commission expires:

Resident State: _____

ATTACHMENT D

CONTRACTOR AFFIDAVIT under O.C.G.A. § 13-10-91(b)(1)

By executing this affidavit, the undersigned contractor verifies its compliance with O.C.G.A. § 13-10-91, stating affirmatively that the individual, firm or corporation which is engaged in the physical performance of services on behalf of CHATHAM COUNTY has registered with, is authorized to use and uses the federal work authorization program commonly known as E-Verify, or any subsequent replacement program, in accordance with the applicable provisions and deadlines established in O.C.G.A. § 13-10-91. Furthermore, the undersigned contractor will continue to use the federal work authorization program throughout the contract period and the undersigned contractor will contract for the physical performance of services in satisfaction of such contract only with subcontractors who present an affidavit to the contractor with the information required by O.C.G.A. § 13-10-91(b). Contractor hereby attests that its federal work authorization user identification number and date of authorization are as follows:

Federal Work Authorization User Identification Number

Date of Authorization

Name of Contractor

Name of Project

Name of Public Employer

I hereby declare under penalty of perjury that the foregoing is true and correct.

Executed on _____, ____, 201__ in _____ (city), _____ (state).

Signature of Authorized Officer or Agent

Printed Name and Title of Authorized Officer or Agent

SUBSCRIBED AND SWORN BEFORE ME
ON THIS THE _____ DAY OF _____, 201__.

NOTARY PUBLIC

My Commission Expires:

SUBCONTRACTOR AFFIDAVIT under O.C.G.A. § 13-10-91(b)(3)

By executing this affidavit, the undersigned subcontractor verifies its compliance with O.C.G.A. 13-10-91, stating affirmatively that the individual, firm or corporation which is engaged in the physical performance of services under a contract with _____ (name of contractor) on behalf of CHATHAM COUNTY has registered with, is authorized to use and uses the federal work authorization program commonly known as E-Verify, or any subsequent replacement program, in accordance with the applicable provisions and deadlines established in O.C.G.A. § 13-10-91. Furthermore, the undersigned subcontractor will continue to use the federal work authorization program throughout the contract period and the undersigned subcontractor will contract for the physical performance of services in satisfaction of such contract only with sub-subcontractors who present an affidavit to the subcontractor with the information required by O.C.G.A. § 13-10-91 (b). Additionally, the undersigned subcontractor will forward notice of the receipt of an affidavit from a sub-subcontractor to the contractor within five (5) business days of receipt. If the undersigned subcontractor receives notice of receipt of an affidavit from any sub-subcontractor that has contracted with a sub-subcontractor to forward, within five (5) business days of receipt, a copy of such notice to the contractor. Subcontractor hereby attests that its federal work authorization user identification number and date of authorization are as follows:

Federal Work Authorization User Identification Number

Date of Authorization

Name of Subcontractor

Name of Project

Name of Public Employer

I hereby declare under penalty of perjury that the foregoing is true and correct.

Executed on _____, ____, 202__ in _____ (city), _____ (state).

Signature of Authorized Officer or Agent

Printed Name and Title of Authorized Officer or Agent

SUBSCRIBED AND SWORN BEFORE ME
ON THIS THE _____ DAY OF _____, 202__.

NOTARY PUBLIC
My Commission Expires:

ATTACHMENT E

CHATHAM COUNTY, GEORGIA

**BIDDER'S CERTIFICATION REGARDING DEBARMENT, SUSPENSION,
INELIGIBILITY AND VOLUNTARY EXCLUSION**

The undersigned certifies, by submission of this proposal or acceptance of this contract, that neither Contractor nor its principals is presently debarred, suspended, proposed for debarment, declared ineligible, or voluntary excluded from participation in this transaction by any Federal department or agency, State of Georgia, City of Savannah, Board of Education or local municipality. Bidder agrees that by submitting this proposal that Bidder will include this clause without modification in all lower tier transactions, solicitations, proposals, contracts and subcontracts. Where the Bidder or any lower tier participant is unable to certify to this statement, that participant shall attach an explanation to this document.

Bidder must verify Sub-Tier Contractors and Suppliers are not debarred, suspended, ineligible, pending County litigation or pending actions from any of the above government entities.

Certification - the above information is true and complete to the best of my knowledge and belief.

(Printed or typed Name of Signatory)

(Signature)

(Date)

NOTE: The penalty for making false statements in offers is prescribed in 18 U.S.C. 1001

END OF DOCUMENT Mod. CC P & C 6/2005

ATTACHMENT F

**Chatham County
Minority and Women Business Enterprise Program
M/WBE Participation Report**

Name of Bidder: _____

Name of Project: _____

Bid No: _____

M/WBE Firm	Type of Work	Contact Person/ Phone #	City, State	%	MBE or WBE

MBE Total _____

WBE Total _____%

M/WBE Combined _____%

The undersigned should enter into a formal agreement with M/WBE Contractor identified herein for work listed in this schedule conditioned upon execution of contract with the Chatham County Board of Commissioners.

Signature _____ Print _____

Phone () _____

Fax () _____

ATTACHMENT G

***Systematic Alien Verification for Entitlements (SAVE)
Affidavit Verifying Status for Chatham County Benefit Application***

By executing this affidavit under oath, as an applicant for a Chatham County, Georgia Business License or Occupation Tax Certificate, Alcohol License, Taxi Permit, Contract or other public benefit as reference in O.C.G.A. Section 50-36-1, I am stating the following with respect to my bid for a Chatham County contract for _____ . [Name of natural person applying on behalf of individual, business, corporation, partnership, or other private entity]

1.) _____ I am a citizen of the United States.

OR

2.) _____ I am a legal permanent resident 18 years of age or older.

OR

3.) _____ I am an otherwise qualified alien (8 § USC 1641) or non-immigrant under the Federal Immigration and Nationality Act (8 USC 1101 et seq.) 18 years of age or older and lawfully present in the United States.*

In making the above representation under oath, I understand that any person who knowingly and willfully makes a false, fictitious, or fraudulent statement or representation in an affidavit shall be guilty of a violation of Code Section 16-10-20 of the Official Code of Georgia.

Signature of Applicant:

Date

Printed Name:

SUBSCRIBED AND SWORN
BEFORE ME ON THIS THE
____ DAY OF _____, 20____

* _____
Alien Registration number for non-citizens.

Notary Public
My Commission Expires:

ATTACHMENT H

GOOD FAITH EFFORT GUIDELINES FOR LOCAL & M/WBE PARTICIPATION

1. When, the County, establish a contract goal, a bidder/proposer must, in order to be responsible and/or responsive, make good faith efforts to meet the goal. The bidder/proposer can meet this requirement in either of two ways. First, the bidder/proposer can meet the goal, documenting commitments for participation by M/WBE firms sufficient for this purpose. Second, even if it doesn't meet the goal, the bidder can document adequate good faith efforts. This means that the bidder/proposer must show that it took all necessary and reasonable steps to achieve an M/WBE goal or other requirement of this part which, by their scope, intensity, and appropriateness to the objective, could reasonably be expected to obtain sufficient M/WBE participation, even if they were not fully successful.

2. In any situation in which the County requires a bidder/proposer to use the good faith efforts mechanism of this rule shall apply. It is up to the County to make a fair and reasonable judgment whether a bidder that did not meet the goal made adequate good faith efforts. It is important to consider the quality, quantity, and intensity of the different kinds of efforts that the bidder has made. The efforts employed by the bidder should be those that one could reasonably expect a bidder/proposer to take if the bidder/proposer were actively and aggressively trying to obtain M/WBE participation sufficient to meet the M/WBE contract goal. Mere pro forma efforts are not good faith efforts to meet the M/WBE contract requirements. We emphasize, however, that your determination concerning the sufficiency of the firm's good faith efforts is a judgment call, meeting quantitative formulas is not required.

3. The rule also strongly cautions County officials against requiring that a bidder/proposer meet a contract goal (i.e., obtain a specified amount of M/WBE participation) in order to be awarded a contract, even though the bidder/proposer makes an adequate good faith efforts showing. This rule specifically prohibits County officials from ignoring bona fide good faith efforts.

4. The following is a list of types of actions which the County should consider as part of the bidder/proposer's good faith efforts to obtain M/WBE participation. It is not intended to be a mandatory checklist, nor is it intended to be exclusive or exhaustive. Other factors or types of efforts may be relevant in appropriate cases.

A. Soliciting through all reasonable and available means (e.g. attendance at pre-bid/pre-proposal meetings, advertising and/or written notices) the interest of all certified M/WBEs who have the capability to perform the work of the contract. The bidder/proposer should solicit this interest within sufficient time to allow the M/WBEs to respond to the solicitation. The bidder/proposer must determine with certainty if the M/WBEs are interested by taking appropriate steps to follow up initial solicitations.

B. Selecting portions of the work to be performed by M/WBEs in order to increase the

likelihood that the M/WBE goals will be achieved. This includes, where appropriate, breaking out contract work items into economically feasible units to facilitate M/WBE participation, even when the prime contractor/consultant might otherwise prefer to perform these work items with its own forces.

C. Providing interested M/WBEs with adequate information about the plans, specifications, and requirements of the contract in a timely manner to assist them in responding to a solicitation.

D.(1) Negotiating in good faith with interested M/WBEs. It is the prime's responsibility to make a portion of the work available to M/WBE subcontractors/sub-consultants and suppliers and to select those portions of the work or material needs consistent with the available M/WBE subcontractors and suppliers, so as to facilitate M/WBE participation. Evidence of such negotiation includes the names, addresses, and telephone numbers of M/WBEs that were considered; a description of the information provided regarding the plans and specifications for the work selected for subcontracting; and evidence as to why additional agreements could not be reached for M/WBEs to perform the work.

(2) A bidder using good business judgment would consider a number of factors in negotiating with subcontractors, including M/WBE sub-contractors/sub-consultants, and would take a firm's price and capabilities as well as contract goals into consideration. However, the fact that there may be some additional costs involved in finding and using M/WBEs is not in itself sufficient reason for a bidder/proposer's failure to meet the contract M/WBE goal, as long as such costs are reasonable. Also, the ability or desire of a prime contractor/consultant to perform the work of a contract with its own organization does not relieve the bidder/consultant of the responsibility to make good faith efforts. Prime contractors/consultants are not, however, required to accept higher quotes from M/WBEs if the price difference is excessive or unreasonable.

E. Not rejecting M/WBEs as being unqualified without sound reasons based on a thorough investigation of their capabilities. The contractor's standing within its industry, membership in specific groups, organizations, or associations and political or social affiliations (for example union vs. non-union employee status) are not legitimate causes for the rejection or non-solicitation of bids in the contractor's efforts to meet the project goal.

F. Making efforts to assist interested M/WBEs in obtaining bonding, lines of credit, or insurance as required by the recipient or contractor/consultant.

G. Making efforts to assist interested M/WBEs in obtaining necessary equipment, supplies, materials, or related assistance or services.

H. Effectively using the services of available minority/women community organizations; minority/women contractors' groups; local, state, and Federal minority/women business assistance offices; and other organizations as allowed on a case-by-case basis to provide assistance in the recruitment and placement of M/WBEs.

5. In determining whether a bidder/proposer has made good faith efforts, County officials may take into account the performance of other bidders/proposers in meeting the contract. For example, when the apparent successful bidder/proposer fails to meet the contract goal, but others meet it, you may reasonably raise the question of whether, with additional reasonable efforts, the apparent successful bidder/proposer could have met the goal. If the apparent successful bidder fails to meet the goal, but meets or exceeds the average M/WBE participation obtained by other bidders/proposers, County officials may view this, in conjunction with other factors, as evidence of the apparent successful bidder/proposer having made good faith efforts.

NAME / TITLE

SIGNATURE

COMPANY

REFERENCE FORM

REFERENCES - \$499,999 or more: On July 25, 2003 the Board of Commissioners directed that all construction projects with a bid of \$499,999 or less, for bidders to be responsive each must provide information on the most recent three (3) projects with similar scope of work as well as other information to determine experience and qualifications as follows. If the contractor has performed any work for the Chatham County Board of Commissioners within the last five (5) years, at least one (1) of the three (3) owner references must be from the appropriate party within the Chatham County Government

- a. Project Name: _____
Location: _____
Owner: _____
Address: _____
City and State: _____
Contact: _____
Phone & Fax: _____
*Architect or Engineer: _____
Contact: _____
Phone & Fax: _____
Email: _____

- b. The awarded bid amount and project start date. _____
- c. Final cost of project and completion date.
- d. Number of change orders. _____
- e. Contracted project completion in days. _____
- f. Project completed on time. Yes _____ No _____ Days exceeded _____

- g. List previous contracts your company performed for Chatham County by Project Title, date and awarded/final cost.
- h. Has contractor ever failed to complete a project? _____ If so, provide explanation.
- i. Have any projects ever performed by contractor been the subject of a claim or lawsuit by or against the contractor? _____ If yes, please identify the nature of such claim or lawsuit, the court in which the case was filed and the details of its resolution.

REFERENCE FORM

REFERENCES - \$499,999 or more: On July 25, 2003 the Board of Commissioners directed that all construction projects with a bid of \$499,999 or less, for bidders to be responsive each must provide information on the most recent three (3) projects with similar scope of work as well as other information to determine experience and qualifications as follows. If the contractor has performed any work for the Chatham County Board of Commissioners within the last five (5) years, at least one (1) of the three (3) owner references must be from the appropriate party within the Chatham County Government

- a. Project Name: _____
Location: _____
Owner: _____
Address: _____
City and State: _____
Contact: _____
Phone & Fax: _____
*Architect or Engineer: _____
Contact: _____
Phone & Fax: _____
Email: _____

- b. The awarded bid amount and project start date. _____
- c. Final cost of project and completion date.
- d. Number of change orders. _____
- e. Contracted project completion in days. _____
- f. Project completed on time. Yes _____ No _____ Days exceeded _____

- g. List previous contracts your company performed for Chatham County by Project Title, date and awarded/final cost.
- h. Has contractor ever failed to complete a project? _____ If so, provide explanation.
- i. Have any projects ever performed by contractor been the subject of a claim or lawsuit by or against the contractor? _____ If yes, please identify the nature of such claim or lawsuit, the court in which the case was filed and the details of its resolution.

REFERENCE FORM

REFERENCES - \$499,999 or more: On July 25, 2003 the Board of Commissioners directed that all construction projects with a bid of \$499,999 or less, for bidders to be responsive each must provide information on the most recent three (3) projects with similar scope of work as well as other information to determine experience and qualifications as follows. If the contractor has performed any work for the Chatham County Board of Commissioners within the last five (5) years, at least one (1) of the three (3) owner references must be from the appropriate party within the Chatham County Government

a. Project Name: _____
Location: _____
Owner: _____
Address: _____
City and State: _____
Contact: _____
Phone & Fax: _____
*Architect or Engineer: _____
Contact: _____
Phone & Fax: _____
Email: _____

- b. The awarded bid amount and project start date. _____
- c. Final cost of project and completion date.
- d. Number of change orders. _____
- e. Contracted project completion in days. _____
- f. Project completed on time. Yes _____ No _____ Days exceeded _____.
- g. List previous contracts your company performed for Chatham County by Project Title, date and awarded/final cost.
- h. Has contractor ever failed to complete a project? _____ If so, provide explanation.
- i. Have any projects ever performed by contractor been the subject of a claim or lawsuit by or against the contractor? _____ If yes, please identify the nature of such claim or lawsuit, the court in which the case was filed and the details of its resolution.

REFERENCE FORM

REFERENCES - \$499,999 or more: On July 25, 2003 the Board of Commissioners directed that all construction projects with a bid of \$499,999 or less, for bidders to be responsive each must provide information on the most recent three (3) projects with similar scope of work as well as other information to determine experience and qualifications as follows. If the contractor has performed any work for the Chatham County Board of Commissioners within the last five (5) years, at least one (1) of the three (3) owner references must be from the appropriate party within the Chatham County Government

a. Project Name: _____
Location: _____
Owner: _____
Address: _____
City and State: _____
Contact: _____
Phone & Fax: _____
*Architect or Engineer: _____
Contact: _____
Phone & Fax: _____
Email: _____

- b. The awarded bid amount and project start date. _____
- c. Final cost of project and completion date. _____
- d. Number of change orders. _____
- e. Contracted project completion in days. _____
- f. Project completed on time. Yes _____ No _____ Days exceeded _____.
- g. List previous contracts your company performed for Chatham County by Project Title, date and awarded/final cost.
- h. Has contractor ever failed to complete a project? _____ If so, provide explanation.
- i. Have any projects ever performed by contractor been the subject of a claim or lawsuit by or against the contractor? _____ If yes, please identify the nature of such claim or lawsuit, the court in which the case was filed and the details of its resolution.

REFERENCE FORM

REFERENCES - \$499,999 or more: On July 25, 2003 the Board of Commissioners directed that all construction projects with a bid of \$499,999 or less, for bidders to be responsive each must provide information on the most recent three (3) projects with similar scope of work as well as other information to determine experience and qualifications as follows. If the contractor has performed any work for the Chatham County Board of Commissioners within the last five (5) years, at least one (1) of the three (3) owner references must be from the appropriate party within the Chatham County Government

a. Project Name: _____
Location: _____
Owner: _____
Address: _____
City and State: _____
Contact: _____
Phone & Fax: _____
*Architect or Engineer: _____
Contact: _____
Phone & Fax: _____
Email: _____

- b. The awarded bid amount and project start date. _____
- c. Final cost of project and completion date.
- d. Number of change orders. _____
- e. Contracted project completion in days. _____
- f. Project completed on time. Yes _____ No _____ Days exceeded _____.
- g. List previous contracts your company performed for Chatham County by Project Title, date and awarded/final cost.
- h. Has contractor ever failed to complete a project? _____ If so, provide explanation.
- i. Have any projects ever performed by contractor been the subject of a claim or lawsuit by or against the contractor? _____ If yes, please identify the nature of such claim or lawsuit, the court in which the case was filed and the details of its resolution.

CHECKLIST FOR SUBMITTING BID

Sign below and submit this sheet with Bid

NOTE: All of the following items must be submitted with your Bid to be considered "responsive".

1. ACKNOWLEDGMENT OF ANY/ALL ADDENDUMS (Page 3 of ITB).
2. **ORIGINAL SURETY BOND (5% OF BID) ALONG WITH SURETY REQUIREMENTS SHEETS FILLED OUT.**
3. **BID SHEET COMPLETELY FILLED OUT AND SIGNED.**
4. **"LIST OF SUBCONTRACTORS" SHEET FILLED OUT WITH ALL SUBCONTRACTORS AND SUPPLIERS.**
5. **"% TO MBE SUBCONTRACTORS/SUPPLIERS' SHEET COMPLETELY FILLED OUT SHOWING \$ AMOUNT AS WELL AS % OF PROJECT THAT IS PROJECTED TO GO TO MBE/WBE SUBCONTRACTORS/SUPPLIERS.**
6. SECTION 2.31 OF ITB - **REFERENCES:** Read this section and submit the correct number of "References" (based on total dollar amount of project) Note: Supply ALL the information that is requested for each Reference. *NOTE: Forms for Reference Information are attached to this Bid Package.*
7. **ALL FIRMS REQUESTING TO DO BUSINESS WITH CHATHAM COUNTY MUST REGISTER ON-LINE AT [HTTP://PURCHASING.CHATHAMCOUNTY.ORG](http://PURCHASING.CHATHAMCOUNTY.ORG).**
8. **COMPLETE AND SUBMIT ALL ATTACHMENTS TO THE ITB (Attachments A thru H). D-2 IS TO BE FILLED OUT FOR EACH SUBCONTRACTOR.**
9. **PROOF OF PRIME CONTRACTOR PRE-QUALIFICATION BY GDOT.**

NAME/TITLE

COMPANY NAME

ADDRESS

CITY/STATE/ZIP

PHONE NUMBER / FAX NUMBER

EMAIL

LEGAL NOTICE
CC NO. 168583
Invitation to Bid

Sealed Bids will be received until 2:00 P.M. on MARCH 8, 2022 and publicly opened in Chatham County Purchasing & Contracting Department, at The Chatham County Citizens Service Center, 1117 Eisenhower Drive, Suite C, Savannah, Georgia 31406, for: BID NO: 22-0015-4 ISLANDS EXPRESSWAY AT OATLAND ROAD OPERATIONAL IMPROVEMENTS AND RESURFACING

PRE-BID CONFERENCE: Due to the current Pandemic, the Pre-Bid Conference will be Audio Only. Contact number for the conference is listed in the Invitation To Bid. The Audio Only Conference will be held on FEBRUARY 22, 2022, at 10:00 A.M. You are encouraged to call and participate.

The Bid Package can be downloaded and printed from the County website <http://purchasing.chathamcounty.org>

For any additional questions regarding this bid, please contact Robert Marshall, Senior Procurement Specialist, at 912-790-1622.or rmarshall@chathamcounty.org

Plans must be purchased at Clayton Digital Reprographics by logging into www.cdrepro.com. Login to DFS. New users must register. For technical support contact CDR at (912) 447-5445, fax (912) 233-7020 or email: cdrwest@cdrepro.com

Bid Bond **is required** at the time of bid. (5% of total bid)
Payment and Performance Bonds (100% of bid) **will be required** for this project at the time of contract award.

CHATHAM COUNTY HAS THE AUTHORITY TO REJECT ALL BIDS AND WAIVE MINOR FORMALITIES.

"CHATHAM COUNTY IS AN EQUAL OPPORTUNITY EMPLOYER, M/F/H. ALL BIDDERS ARE TO BE EQUAL OPPORTUNITY EMPLOYERS"

MARGARET H. JOYNER, PURCHASING DIRECTOR

SAVANNAH NEWS/PRESS INSERT: Feb. 4, 2022

Please send affidavit to:
Chatham County Purchasing & Contracting Department
1117 Eisenhower Drive, Suite C
Savannah, Georgia 31406
(912) 790-1622